

SiC Active Harmonic Filter for Variable Frequency Drives

Objectives:

- Increase the adoption of WBG devices by developing and demonstrating on a commercial chiller a 150 Amps rated active harmonic filter that is 50% smaller and 20% projected lower cost (TRL 6)

Major Milestones:

- Validate a 150 amps capability at 480V and 40 kHz (Go/No-Go Month 9)

Deliverables:

- Provide working hardware and data from a demonstration of a SiC 150 amp AHF prototype in a relevant environment achieving less than 5 % current total harmonic distortion (TRL 6)

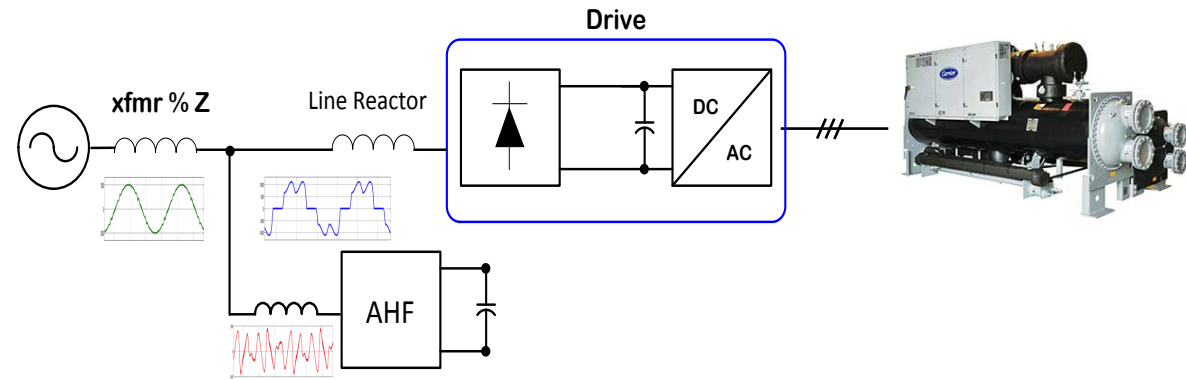

PI: Luis Arnedo
 Email: arnedol@utrc.utc.com
 Phone: (860) 610-7163

WBG Technology Impact

This project will accelerate the adoption of wide bandgap devices for commercial applications by enabling higher power density and lower cost active harmonic filters that can be used as power quality point of load solution. In addition to HVAC applications, this technology could be used for premium variable frequency drive providing a significant market opportunity for the application of WBG devices

Projected Benefits of a SiC AHF

Rating		Commercial AHF			Estimated WBG AHF		
Current Amps	Power KVA	Silicon IGBT			SiC MOSFET		
		Weight Kg	Power Density Kw/liter	Cost \$/Amp	Weight Kg	Power Density Kw/liter	Cost \$/Amp
60	50	100	0.26	133	60	0.52	107
120	100	122	0.44	100	73	0.87	80
200	166	184	0.49	90	110	0.99	72
300	249	229	0.63	83	137	1.26	67

Additional impacts

1. This application could expand the market of WBG into high power applications
2. It is expected that this technology, once commercialized, would enhance US competitiveness increase US manufacturing jobs for chillers and power electronics.
3. TRL levels :

At project start: TRL 4

Expected at project completion: TRL 6